

DEVAR Inc.

706 Bostwick Avenue, Bridgeport, CT 06605
TEL: 203-368-6751 FAX: 203-368-3747
1-800-566-6822 www.devarinc.com

Model 332

ALARM / CONTROLLER



INDUSTRIAL CONTROL EQUIPMENT

MANUAL NO. 990620A

TABLE OF CONTENTS

Section	Title	Page No.
I	General Description	1
II	Specifications	3
III	Installation	5
IV	Operation	7
V	Recalibration	9
VI	Power Supply Options	12
VII	Troubleshooting	13
VIII	Parts List	18

Addendum A Model 332-AP Pump Controller

TABLES AND ILLUSTRATIONS

Figure	Title	Page No.
3.1	General Dimensions 332W	5
3.2	General Dimensions 332P	6
3.3	Field Wiring	6
4.1	Dip Switch Setting Table	8
5.1	Input Range Calibration Table	10
5.2	Display Recalibration Procedure	11
5.3	Decimal Point Location	11
6.1	Modification for 24 VDC Power	12
7.1	Schematic	14
7.2	Component Location, Display Board	15
7.3	Component Location, Circuit Board	16
7.4	Component Location, Power Supply	17

SECTION I GENERAL DESCRIPTION

1.1 General

The Devar Model 332 Alarm/Controller is a high accuracy multipurpose instrument, providing process indication, two separate alarm channels, independently adjustable set and reset points, substantial relay contact rating and simplicity of adjustment, with set and reset points read directly from the digital display.

1.2 Theory of Operation

Used as a simple alarm, the 332 monitors a single voltage or current input signal and compares it to the trip point setting. When the input signal reaches the trip point setting an alarm is initiated and the internal relay, which is normally energized for fail-safe operation, will de-energize.

1.3 Dual Channel Operation

The 332 monitors a single voltage or current input and provides two output channels with independent trip point adjustments and environmentally sealed, 10 amp, SPDT relays. Each channel can be set to alarm on an increasing or decreasing input signal by means of an internal DIP switch setting. A red LED turns on indicating which channel has alarmed and the bright red backlit display begins flashing on and off, alerting an observer to the alarm condition. The flashing display option can be disabled if desired.

1.4 Set Point and Reset Point

A special feature of the 332 is the ability to set not only the alarm trip point, but also the reset point (e.g. the alarm could be set to trip if the input were to go above 75%, but not to reset until the input fell below 50%). Both set and reset points can be adjusted anywhere between -5% and +105% of the input range. This feature makes the 332 ideal as a simple on/off controller. A typical application could be level control in a tank. If the desired level was at 50%, a pump could be turned on when the level fell below 50% and turned off once the level rose above some pre-specified value. Should the level continue to drop (e.g. below 40%) a second pump could be activated until the level was corrected.

1.5 Display

The 332 provides a large 3-1/2 digit display with bright red backlit digits, which can be easily seen in bright ambient light or in total darkness. This display is used to monitor the input signal as well as to set the alarm trip and reset points. The display is calibrated to read in percent, however, it can be factory calibrated to read directly in engineering units such as °F, °C, PSI, GPM, etc.

1.6 Packaging and Shielding

The 332 is housed in a rugged steel enclosure and is available in either panel mounted or wall mounted versions. The internal relays are epoxy encapsulated in a separate steel box mounted inside of the larger enclosure. This method of assembly provides environmental isolation for the relays as well as electrical shielding for the electronic circuitry. In addition, all lines going to the electronic circuitry have been RFI filtered.

1.7 Power

The 332 is powered from 115 VAC, however, 230 VAC and 24 VDC operations are also available. When AC powered, The 332 provides a 24 VDC output which can be used to power an external two wire transmitter.

SECTION II SPECIFICATIONS

2.1 General

a. Repeatability	0.1 % of span
b. Resolution Trip Adjust	0.1 % of span
c. Display Accuracy	Reading \pm 2 Counts
d. Indication	Input, Set Points, Reset Points; Scale 0 to 100% Standard (Non-standard Ranges Between \pm 1999 Counts)
e. Set Point (dual)	-5% to +105%
f. Reset Point (dual)	-5% to +105%
g. Operating Temp. Alarm	-10 to +70° C
h. Operating Temp. Display	0 to +60° C
i. Storage Temperature	-20 to +80° C
j. Temperature Effect	0.018%/°C, max.
k. Display	1/2 inch High, 3.5 Digit LCD Backlit, Red Digits on Black
l. Power	115 V, 50/60 Hz, 6 VA Option E71: 230 V, 50/60 Hz, 6 VA Option E92: 24/28 VDC, 90 mA (Non-isolated)

2.2 Inputs

a. Standard Ranges	332-1	0/5 mA, Ri = 200 Ohms
	-2	1/5 mA, Ri = 200 Ohms
	-3	4/20 mA, Ri = 50 Ohms
	-4	10/50 mA, Ri = 20 Ohms
	-5	0/10 mA, Ri > 10 meg
	-6	0/5 V, Ri > 10 meg
	-7	0/1 mA, Ri = 1K Ohms
	-8	0/1 V, Ri > 10 meg
	-9	1/5 V, Ri > 10 meg
	-X	Non-standard, Specify

2.3 Alarm Contacts

- a. Relays (2) SPDT,
Epoxy Encapsulated
- b. Mechanical Life..... 20 Million Operations
- c. Electrical Life..... 100,000 Operations at
8 Amps, 240 VAC, 24 VDC,
Resistive

50,000 Operations at
10 Amps (N.O. contact)
5 Amps (N.C. contact)
120 VAC, Resistive

30,000 Operations at
7.2 Motor Run Amps,
45 Lock Rotor Amps,
120 VAC

10,000 Operations at
5 Motor Run Amps,
30 Lock Rotor Amps,
240 VAC
- d. Maximum Switched Power..... 200 W DC, 2000 VA AC
- e. VDE Contact Rating..... 8 Amps, 250 VAC
- f. UL/CSA Contact Rating..... 10 Amps, 240 VAC,
Resistive,
8 Amps, 24 VDC, Resistive
1 /3 HP, 120 VAC
1 /2 HP, 240 VAC

2.4 Housing

- a. Indoor Type..... Panel or Wall Mounted,
Gray Baked Enamel Over
Zinc Plated Steel
- b. Weight 2.3 lbs.

SECTION III INSTALLATION

3.1 Mounting

The 332 Alarm/Controller is available, either as a wall mounted (332W) or as a panel mounted (332P) unit. The wall mounted unit is attached to the wall by means of two #6 or #8 screws (see fig. 3.1). The panel mounted unit is inserted through the front of the panel then locked in place by a U-shaped bracket, which is screwed to the rear of the housing using two #6 screws (see fig. 3.2).

3.2 Field Wiring

Field wiring connections are made to a 12 point, compression type terminal block, which can accept up to 14 AWG wire (see fig. 3.3).

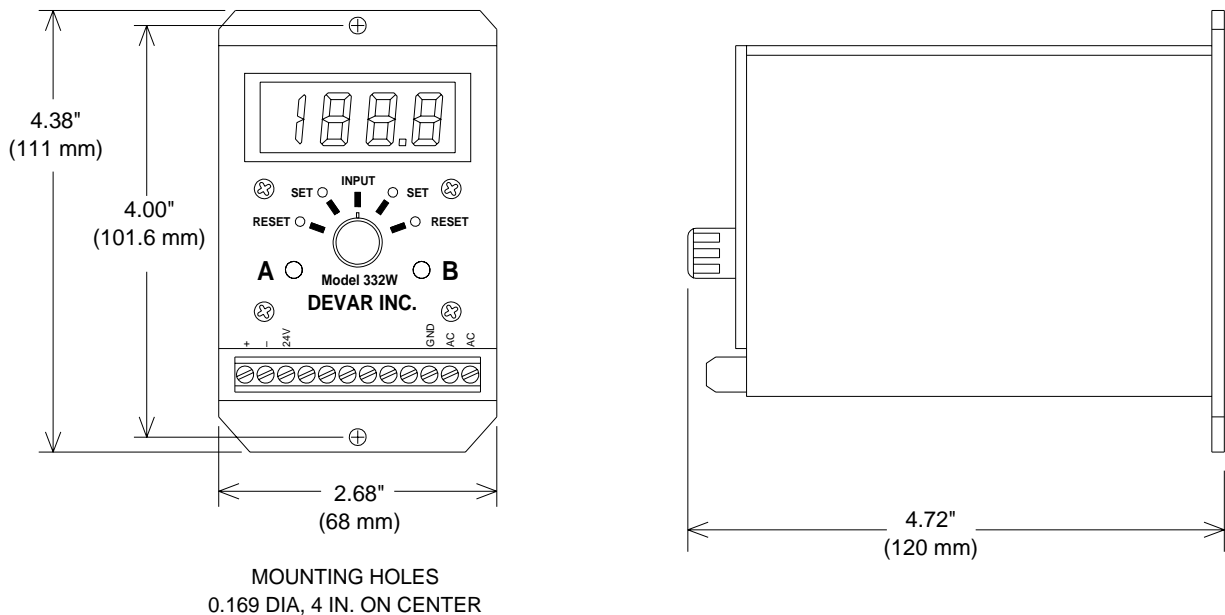
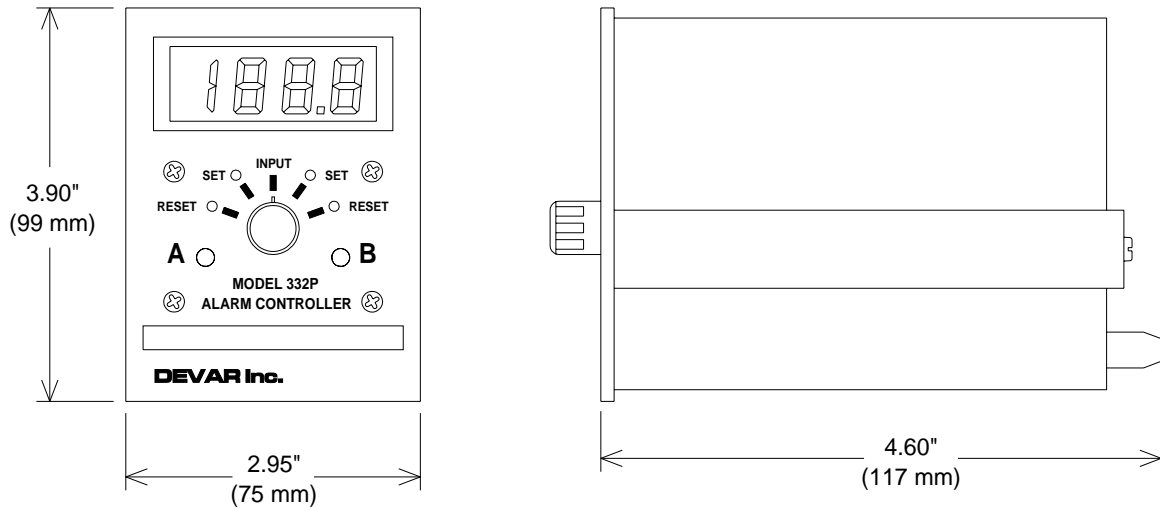

Figure 3.1 – General Dimensions 332W



PANEL CUTOUT
 3.67" (93.2 mm) x 2.71" (68.8 mm)
 TOLERANCE ±0.015 (±0.38 mm)

Figure 3.2 – General Dimensions 332P

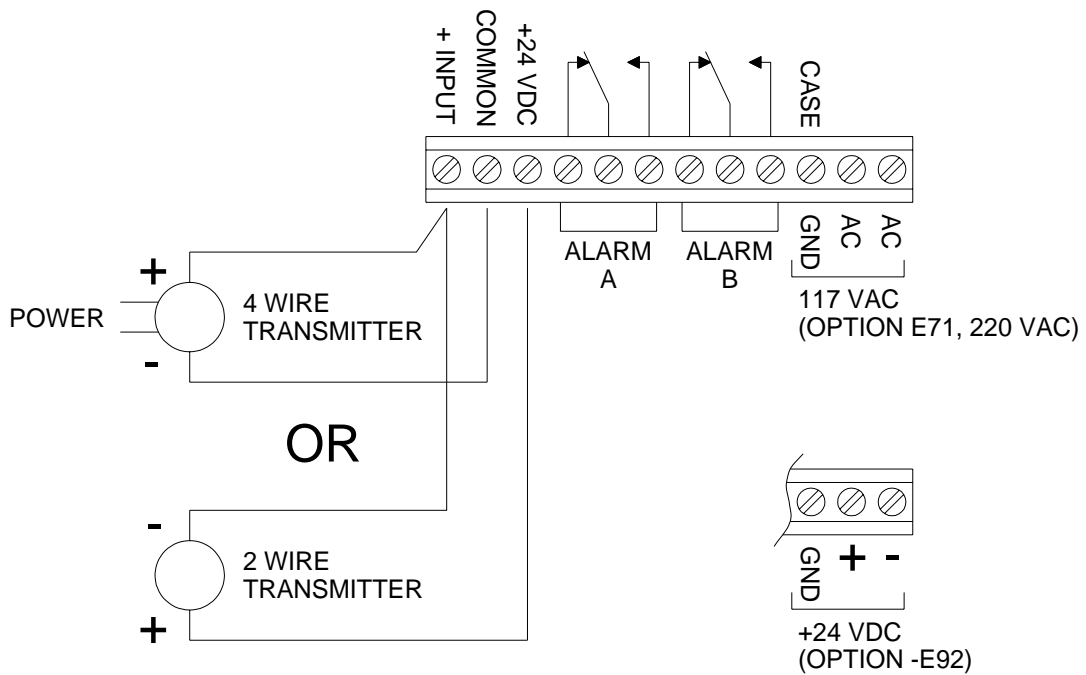

Figure 3.3 – Field Wiring

SECTION IV OPERATION

4.1 High-Low Selection

Each channel of the 332 Alarm/Controller can be independently configured for high alarm or low alarm operation by setting the internal dip switches. To do this remove the cover from the top of the 332 and set the dip switches to the proper positions as specified in figure 4.1.

4.2 Alarm Indication

The 332 has been factory configured so that if either channel goes into alarm the display will begin to flash. The display will continue to flash as long as one of the channels remains in the alarm condition. If this feature is not desired it can be disabled by removing diodes D3 and D4 from the PC board. See figure 7.3 for the location of diodes D3 and D4. An alarm condition is also indicated by two red LEDs, one for channel A and one for channel B. These LEDs will light on alarm. The operation of the LEDs is not affected by disabling the flashing display.

4.3 Trip Point Selection

To set the trip point turn the selector knob to the **Set** position then adjust the trip point pot until the desired trip point appears on the display. To set the reset point, turn the selector knob to the **Reset** position, then adjust the reset pot until the desired reset point appears on the display. For a high alarm, the reset point should be set at least 0.1% below the trip point, and for a low alarm, at least 0.1 % above the trip point, this is to prevent relay chattering when the input is exactly at the trip point. However, we recommend a dead band setting of 1% or more, in order to exceed the noise normally found on the input signal, in factory environments. Once the trip and reset points are set for both channels, turn the selector knob to **Input** (the center position). The input will now be displayed.

4.4 Trip Point Monitor

The set and reset points can be set whenever power is applied to the unit. An input signal is not required. The set and reset points can also be monitored at any time, while the unit is in operation. Turning the selector switch to display the trip or reset point has no effect on the operation of the unit.

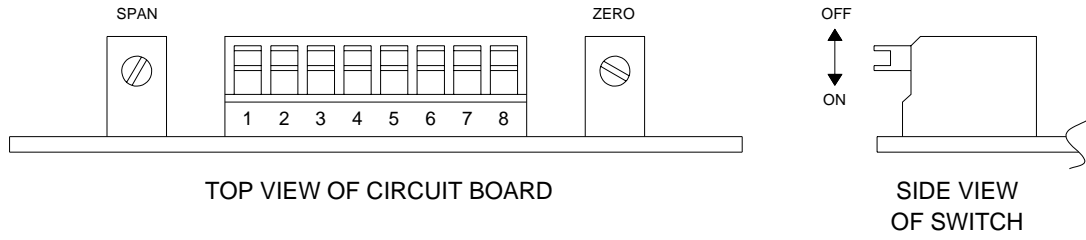

ALARM	ACTION	ON POSITIONS	OFF POSITIONS
A	HI	1, 2	3, 4
	LOW	3, 4	1, 2
B	HI	5, 6	7, 8
	LOW	7, 8	5, 6

Figure 4.1 – Dip Switch Setting Table

SECTION V RECALIBRATION

5.1 Standard Input Calibration

The 332 Alarm/Controller is calibrated to display 00.0 to 100.0 for any standard input range. To change the input from one standard range to another standard range, the proper values for resistors R107, R109 and R110 must be selected. The value of these resistors, for standard input ranges, is listed in figure 5.1. The location of these resistors can be found in figure 7.3.

5.2 Span and Zero Adjustment

Once the proper calibrating resistors have been installed, turn the selector switch to the **Input** position and apply an input signal to the unit. Adjust the span and zero pots (see fig. 7.3) until the display is calibrated to read 00.0 to 100.0.

5.3 Nonstandard Input Calibration

The 332 Alarm/Controller can also be calibrated for nonstandard input ranges. To do this the values of resistors R107, R109, and R110 must be calculated so that the new input range will produce an output voltage of 0 to 4.75 V at pin 14 of amplifier U2. See figure 7.1 for the circuit schematic and figure 7.3 for the location of amplifier U2. Once the resistors have been installed, an input signal must be applied and the span and zero pots adjusted, as described in paragraph 5.2.

5.4 Engineering Units

The display of the 332 Alarm/Controller can also be calibrated to read directly in engineering units. To do this requires the removal of jumper J2, the selection of resistors R28 and R29, and the positioning of jumper J1, for decimal point selection. These components are located on turret terminals on the PC board, behind the display (see fig. 7.2).

5.5 Display Recalibration

To recalibrate the display, the value of resistors R28 and R29 can be calculated by following the steps outlined in figure 5.2. See figure 5.3 for decimal point selection. Once these resistors and jumpers have been installed the unit must be calibrated. To do this, apply a signal to the input terminals of the 332. Input the bottom of the range and adjust the zero pot for the proper display reading, then input the top of the range and adjust the span pot. Repeat this procedure until the display is calibrated. See figure 7.3 for the location of the span and zero pots.

Input Range	R109		R110		R107	
	Ohms	Part No.	Ohms	Part No.	Ohms	Part No.
0/1 mA	1,000	223737-0021	84,500	223737-0036	243,000	223737-0131
0/5 mA	200	514490-2000	84,500	223737-0036	243,000	223737-0131
1/5 mA	200	514490-2000			82,500	223737-0076
4/20 mA	49.9	514490-0499			82,500	223737-0076
10/50 mA	20	223737-0181			82,500	223737-0076
1/5 V			4,320	223737-0026	82,500	223737-0076
0/1 V			84,500	223737-0036	243,000	223737-0131
0/5 V			3,320	223737-0138	243,000	223737-0131
0/10 V			1,500	223737-0059	243,000	223737-0131

Figure 5.1 – Input Range Calibration Table

To Recalibrate Display	Example
1. Specify New Range	-45.0 to 150.0 °F
2. Calculate Span Counts (Ignore decimal point)	1500 $\frac{-(-) 450}{1950}$ counts
3. Note offset counts	-450 counts
4. Calculate Scaling Factor $a = (\text{span}) \times 4.2283 \times 10^{-5}$	$(1950) \times 4.2283 \times 10^{-5} = 0.08245$
5. Calculate Resistor R19 $R19 = \frac{45300 \times a}{1-a}$	$\frac{45300 \times 0.08245}{1 - 0.08245} = 4070.6$
6. Select Closest Standard 1% Resistor, 50 PPM/°C or better	R19 = 4020 Ohms
7. Calculate millivolt Offset $V = (\pm \text{Offset}) \times 2 \times 10^{-4}$	$(-450) \times 2 \times 10^{-4} = -0.09$ Volts
8. Calculate Offset Resistors $\frac{R29}{R28} = \frac{6.235}{5 - V} - 1$	Using R28 = 20,000 $\left[\frac{6.235}{5 + 0.09} - 1 \right] \times 20,000 = 4499$
9. Select Closest Standard 1% Resistor, 50 PPM/°C or better	R28 = 20K R29 = 4.53K

Figure 5.2 – Display Recalibration Procedure

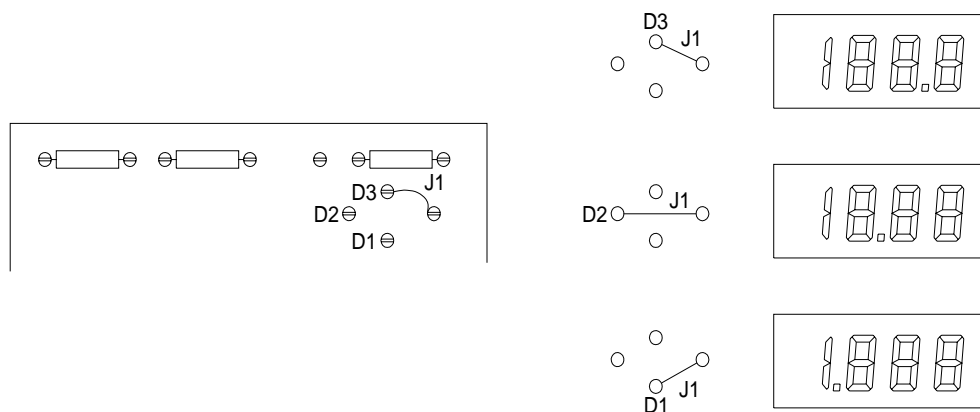

Figure 5.3 – Decimal Point Location

SECTION VI POWER SUPPLY OPTIONS

6.1 Conversion to 230 VAC Power

To change the power supply operation from 115 to 230 VAC, a jumper "J3" must be added on the power supply board and the track must be cut in two places. Reference figure 7.1 for the circuit schematic and figure 7.4 for the location of the jumper and the cut tracks.

6.2 Conversion to 24/28 VDC Power

For 24 to 28 VDC operation, remove transformer "T1" and diode bridge "DB1" from the power supply board, add diode IN4002 (380666-01) and jumpers "J4" and "J5". Reference figures 6.1, 7.1, and 7.4.

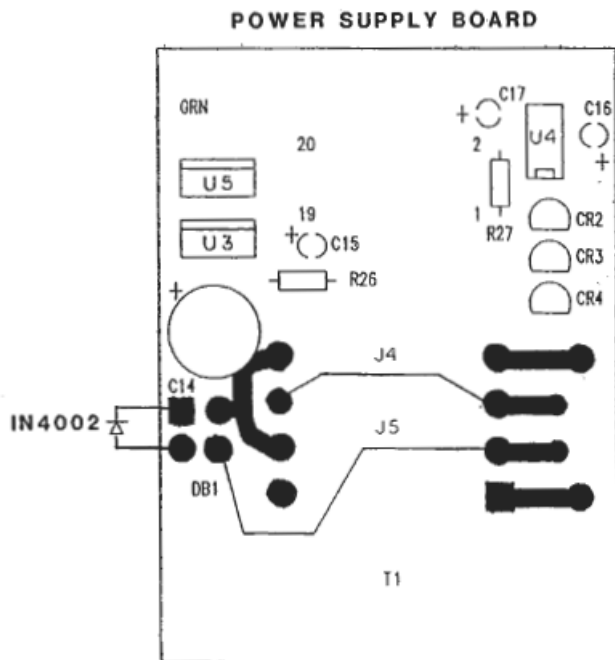

Figure 6.1 – Modification for 24 VDC Power

SECTION VII TROUBLESHOOTING

7.1 Check Points

If the 332 Alarm/Controller is not operating properly, check the following:

- a. That the unit is receiving power.
- b. That all terminals are wired correctly and that terminal screws are tight.
- c. That the reset point is below the set point for a high alarm.
- d. That the reset point is above the set point for a low alarm.

7.2 Troubleshooting

If the cause of the problem is not found, disconnect all connections, except power, from the terminal block. Make the following tests to determine in, which part of the circuit the problem lies.

- a. Check for +24 volts between field terminals 3(+) and 2(-).
- b. Turn the selector switch to the **set** and **reset** positions and check to see that the display responds to adjustment of set and reset pots.
- c. Short input terminals 1 and 2, and turn the selector switch to the input position. For a 0 to 100% display, the reading should be 00.0, if the unit has been calibrated for a zero based input such as 0 to 10 volts. The display should read -25.0 if the unit has been calibrated for an input with a 25% offset such as 4 to 20 mA.
- d. To troubleshoot the circuit, refer to the schematic, figure 7.1 and component location drawings, figures 7.2, 7.3, and 7.4.

7.3 Replacement Parts

Replacement parts may be ordered, by their part number from Devar Inc. Most capacitors, diodes and resistors are readily obtainable from local electronics distributors. Reference Section VIII for a complete list of parts used in the 332.

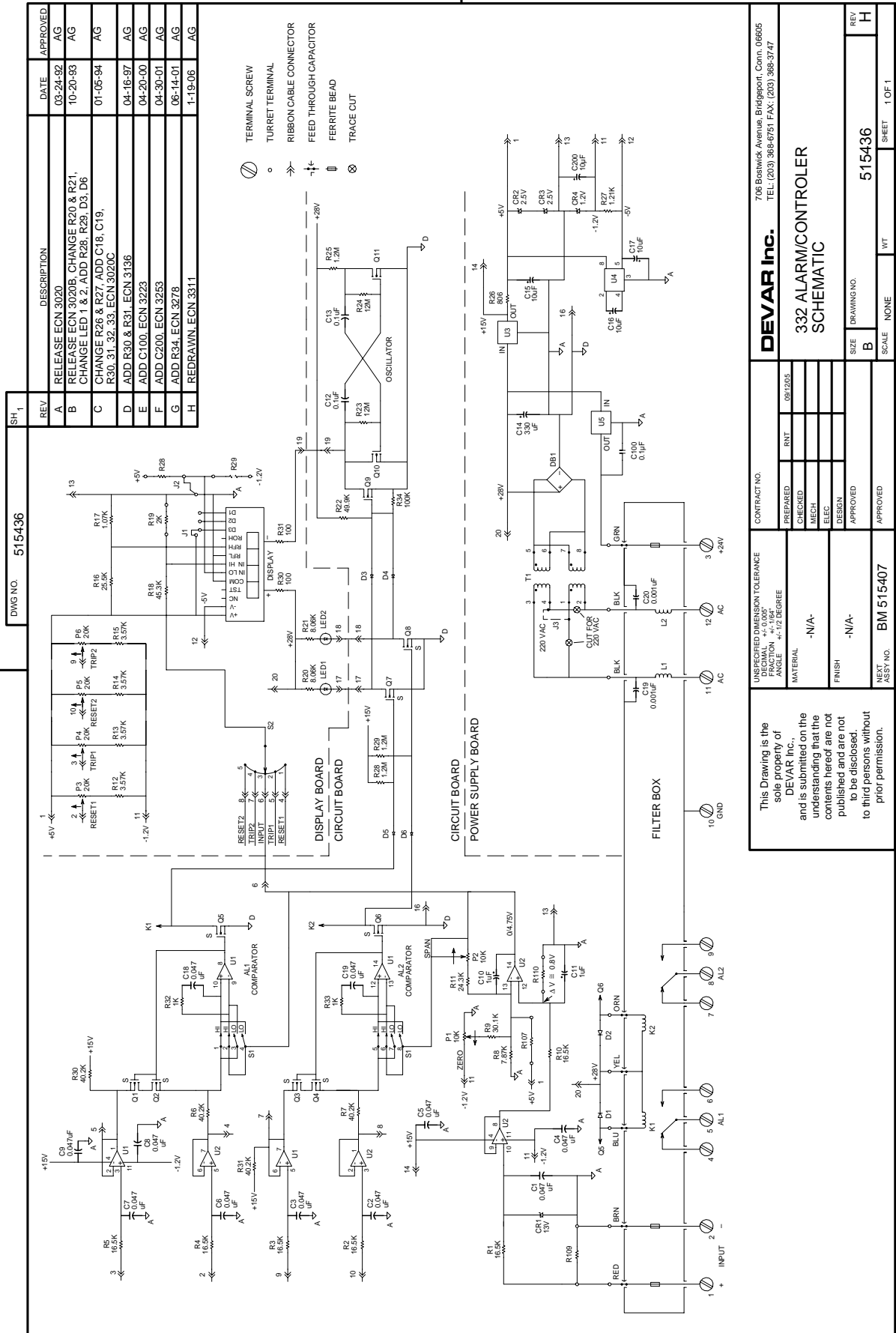

Figure 7.1 - Schematic

<p>DEVAR Inc. 706 Boonick Avenue, Bridgport, Conn. 06605 TEL: (203) 368-6751 FAX: (203) 365-3747</p>	
<p>332 ALARM/CONTROLLER SCHEMATIC</p>	
<p>CONTRACT NO. 201205</p>	<p>REV H</p>
<p>PREPARED</p>	<p>SIZE B</p>
<p>CHECKED</p>	<p>SCALE NONE</p>
<p>MECH</p>	<p>W/T</p>
<p>ELEC</p>	<p>DRAWING NO. 515436</p>
<p>DESIGN</p>	<p>SHEET 1 OF 1</p>
<p>APPROVED</p>	<p>BM 515407</p>
<p>UNSPRIFIED DIMENSION TOLERANCE DECIMAL: +0.005" FRACTION: +0.005" ANGLE: +1/2 DEGREE</p>	<p>MATERIAL -N/A-</p>
<p>FINISH -N/A-</p>	<p>APPROVED</p>
<p>This Drawing is the sole property of DEVAR Inc., and is submitted on the understanding that the contents hereof are not published and are not to be disclosed, to third persons without prior permission.</p>	<p>APPROVED</p>

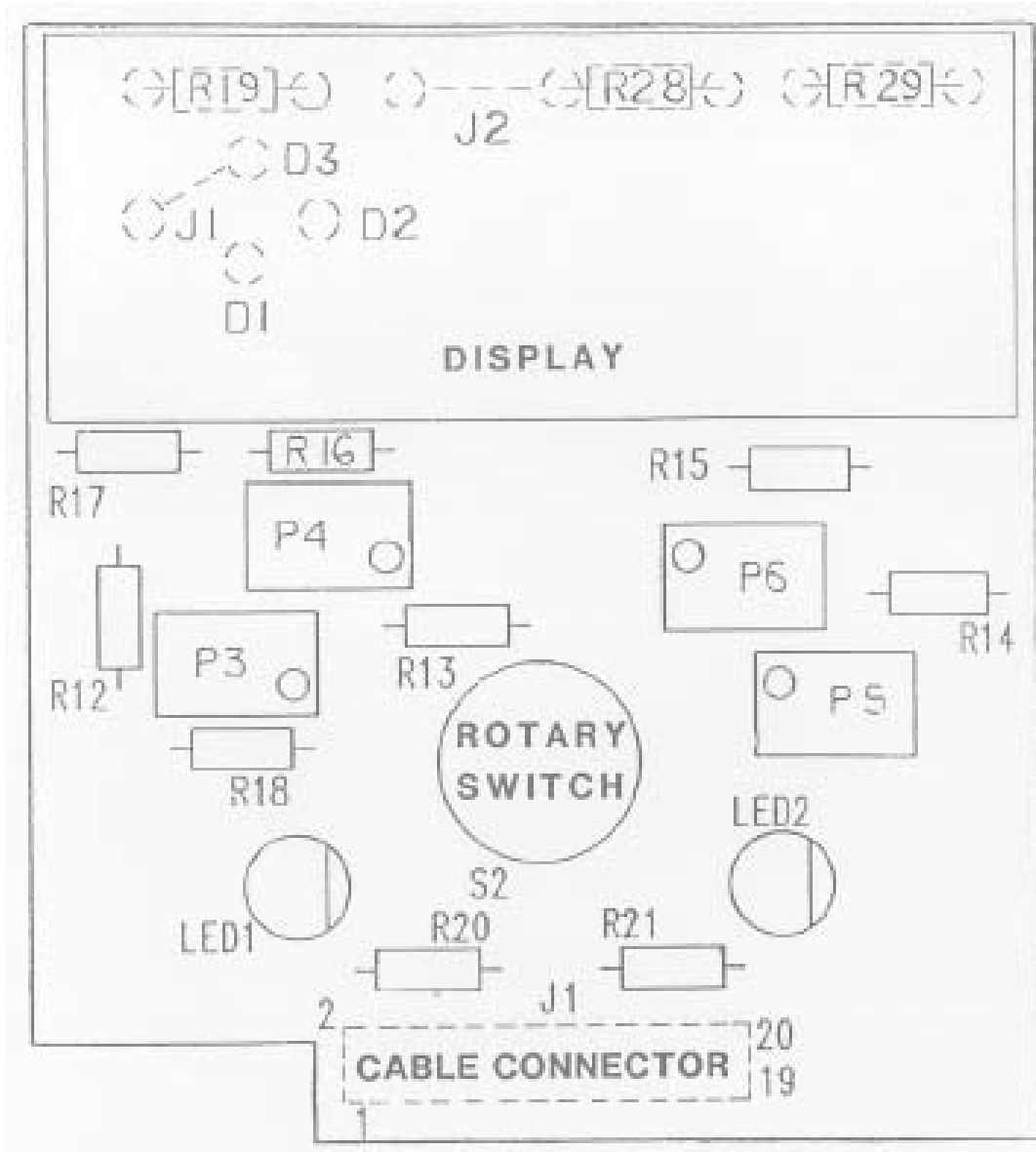

Figure 7.2 - Component Location, Display Board

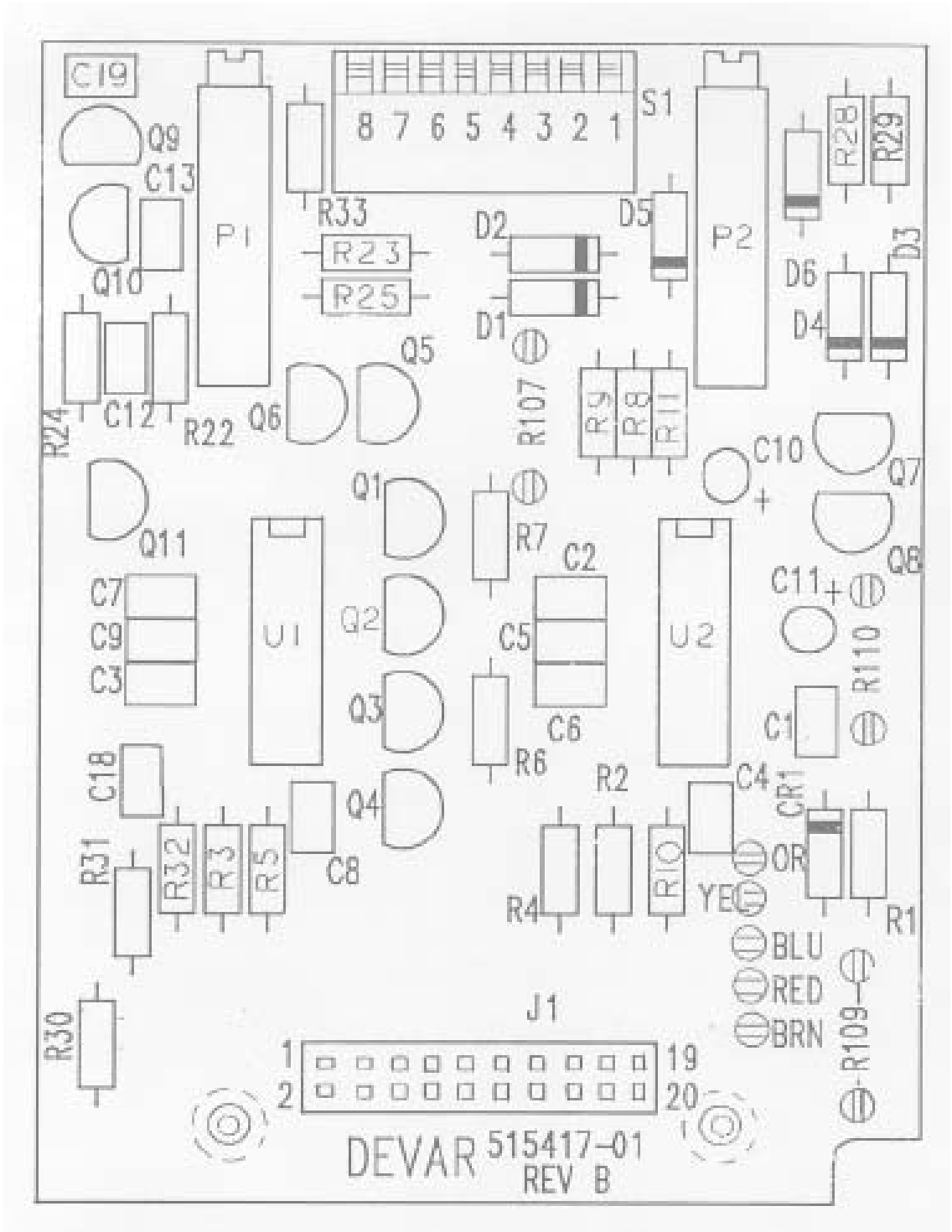

Figure 7.3 - Component Location, Circuit Board

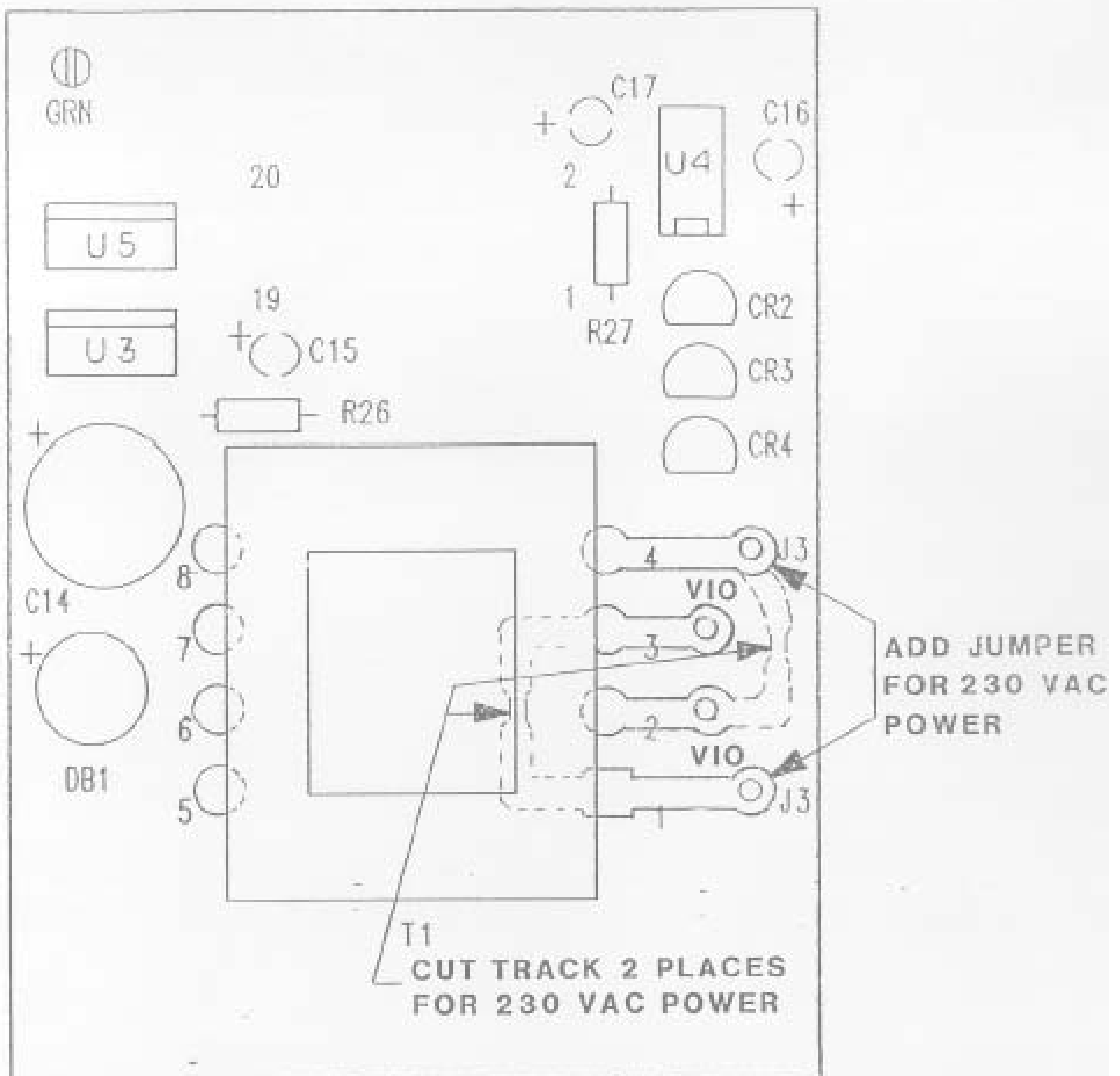

Figure 7.4 - Component Location, Power Supply

SECTION VII PARTS LIST

7.1 Parts relating to calibration can be found in Fig. 5.1, The Input Range Calibration Table. To order spare or replacement parts, contact your local Devar Inc. representative. Whenever possible, specify items by description and part number.

7.2 Resistors, 1% Metal film Part Number

R1,2,3,4,5,10	16.5K	223737-0099
R6,7,30,31	40.2K	223737-0048
R8	7.87K	223737-0042
R9	30.1K	223737-0009
R11	24.3K	223737-0137
R23,24	12M (5%)	221862-0024
R25,28,29	1.2M (5%)	222087-0015
R12,13,14,15	3.57K	223737-0063
R16	25.5K	223737-0008
R17	1.07K	223737-0053
R18	45.3K	223737-0085
R19,20,21,27	2K	223737-0058
R26	1.5K	223737-0059
R32,33	1K	223737-0021

7.3 Potentiometers

P1,2	10K, 3006Y	381098-0010
P3,4,5,6	20K, 3299W	381355-0011

7.4 Capacitors

C1 thru C9,18,19	0.047 μ F, 50WV, Ceramic	382473-0001
C10,11,15,16,17	10 μ F, 20WV, Tantalum	380767-0001
C12,13	0.1 μ F, 50WV, Ceramic	382473-0001
C14	330 μ F, 50WV, Electrolytic	514491-0001

7.5 Semiconductors

Q1 thru Q11	N Channel, V-MOS	514404-0001
D1,2,3,4,5,6	Diode, IN4153	222095-0001
CR1	Zener, 13V, IN5243B	381071-0005
LED1,2	LED, HLMP-4700	514472-0002
DB1	Diode Bridge, PF10	380766-0002

7.6 Integrated Circuits

U1,2	Op-Amp, Quad, TLC27L4IN	514841-0001
U3	Regulator, 15V, LM340T-15	381584-0001
U4	DC to DC Converter, TSC7660	514735-0001
U5	Regulator, 24V, MC7824CT	513410-0001
CR2,3	Reference, 2.5V, LM385B-2.5	382209-0003
CR4	Reference, 1.2V, LM385B-1.2	382209-0001

7.7 Switches

S1	Switch, DIP	513655-0002
S2	Switch, Rotary	515416-0001

7.8 Transformer

T1	Power Transformer	514797-0004
----	-------------------	-------------

7.9 Display 515413-0001**7.10 Cable Assembly** BM 515433-0001**7.11 Filter Box Assembly** BM 515412-0001

Includes: Relays, Terminal Block and EMI
Filters, Epoxy Encapsulated

Model 332-AP

Alternating Duplex Pump Controller

The specifications for the Model 332 Alarm/Controller and the Model 332-AP Duplex pump controller are exactly the same except for the action of the relays. The Model 332-AP is specifically designed for pump control applications. The 332-AP has two channels, one for each pump. Each channel provides independently adjustable trip (pump-on) and reset (pump-off) set points. As with the standard 332, the alarm action (high or low) must be preset for each of the two channels. For pump-up applications, the alarm action for both channels is set to low. For pump-down applications the alarm action for both channels is set to high. Note that with the 332-AP the alarm action for both channels will always be the same. Note also that for pump-up applications the reset (pump-off) point must be set above the set (pump-on) point and for pump down applications the reset (pump-off) point must be set below the set (pump-on) point. When the input level crosses the first trip point one of the two output relays will energize and the normally open contact will close, turning the pump on. Output relays alternate each time the trip point is crossed. This allows the work load to be shared between the two pumps, with only one pump working at a time. Should the input level cross the second trip point, then the pump that is not operating will also turn on and both pumps will run simultaneously until the first reset point is reached. Unlike the standard 332 the relay coils are energized while in the tripped (pump-on) state, therefore if power is removed from the 332-AP the relay contacts will go into the pump-off position.